



GIGANET CABINETS AND ENCLOSURE

GIGANET Networking Solutions provides a comprehensive range of cabinets and enclosures that can be used in computer and telecommunication technology industry. GIGANET products include Server racks, free standing racks, Wall mount racks and accessories. Under the GIGANET brand we also manufacture and provide a 25 year warranty and certified training for a complete end to end range of structured cabling infrastructure solutions to support converged applications on both Copper and Fibre.



GIGANET NETWORKING SOLUTIONS LTD

www.giga-net.co.uk

GN-001 NETWORK SERVER CABINET (MESH DOOR)**Structure****Product Information**

- Exquisite design with precise craftsmanship.
- Install castor and adjustable feet are available at the same time.
- Optional plinth enables cabinet to stay in a fixed position, meeting requirements of under-base cable entry/ventilation and prevention.
- Front arc mesh door and rear flat mesh door. Adjustable under-base cable entry to meet various requirements.
- Removable side panels, easy to install and maintain
- Flat pack is optional to reduce the shipment cost, easy to assembly.

Offering Accessories 19" Rack Height 42U width 800mm and depth associated accessories 3 fixed shelf, 4 fans 4 castors 4 feet 40 set cage nuts.

Main material: SPCC cold rolled steel **Thickness of Steel:** mounting profile: 2.0mm; others: 1.2mm.

Surface finish: Surface: degreasing, acid pickling, phosphoric, dip-coat primed, powder coat;

Loading capacity: Static loading: 800KG **Degree of protection:** IP20.

STANDARD: Comply with ANSI/EIA RS-310-D、IEC297-2、DIN41494 ;

PART1、DIN41494; PART7、GB/T3047; 2-92STANDARD.

Specifications

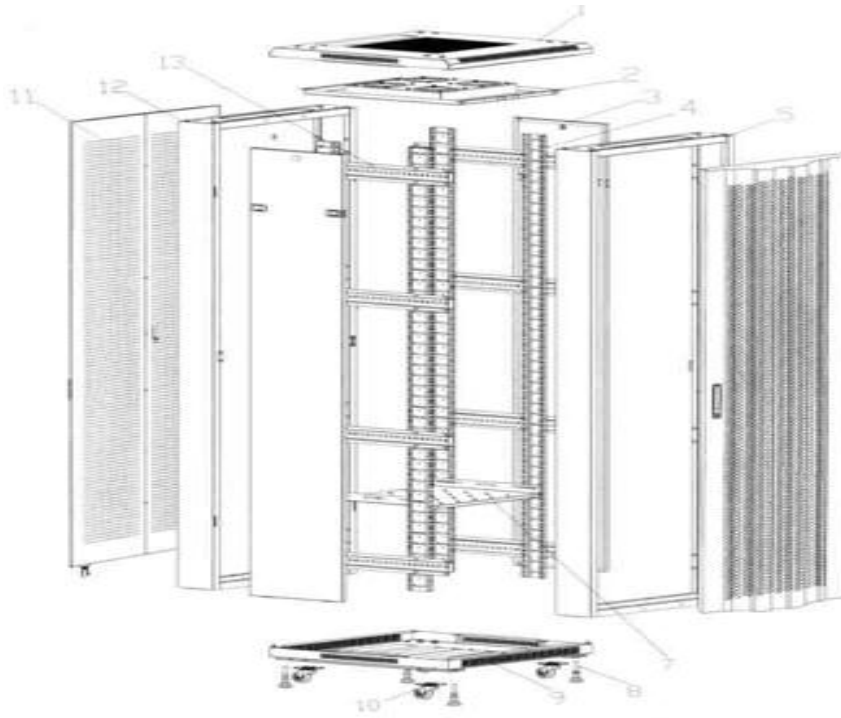

Model No	Capacity (U)	Width (mm)	Depth (mm)	Height (mm)	Packing dimension W*D*H	Volume (CBM)
GN-001-8842	42	800	800	2055	830*830*2070	1.4260
GN-001-81042	42	800	1000	2055	830*1030*2070	1.8700

Definition of Color

Color		
RAL9004	Black	

GN-002 NETWORK SERVER CABINET (GLASS DOOR)**Structure****Product Description**

- Elegant look, profound technical, precise dimension, with modern look, add value to your projects.
- Easy to fix concentrated distribution unit into frame.
- Popular front door made by smoky gray color toughened glass.
- Install caster and support feet at the same time.
- Wire path on the top and bottom can be closed, and wire holes dimension can be changed as request.
- Optional bottom seat for stable stand, bottom wiring, bottom cold ventilation and prevent rats.
- Side door and rear/front door can be taken down easily.

Product Information

Exquisite design with precision dimensions and craftsmanship Color: Computer gray or black, vented front/rear doors enable ventilated operation Swiveling wheels and legs can be jointly installed to withstand up to 800kg maximum carrying capacity and 350kg mobile carrying capacity Several lockable wining holes on top/bottom, size of the large hole at the bottom adjustable Easy-to-disassemble front/rear/left/right doors enable convenient operation from any side of the cabinet Optional installation of base enables the cabinet to stay in a fixed position while meeting requirements of under-base wiring/ventilation Linkage cabinet.

Offering Accessories 19" Rack Height 42U width 800mm and depth associated accessories 3 fixed shelf, 4 fans 4 castors 4 feet 40 set cage nuts.

Main material: SPCC cold rolled steel; **Thickness of Steel:** mounting profile: 2.0mm; others: 1.2mm.

Surface finish: Surface: degreasing, acid pickling, phosphoric, dip-coat primed, powder coat;

Loading capacity: Static loading: 800KG **Degree of protection:** IP20

STANDARD: Comply with ANSI/EIA RS-310-D, IEC297-2, DIN41494 ;

PART1, DIN41494; PART7, GB/T3047; 2-92STANDARD.

Specifications

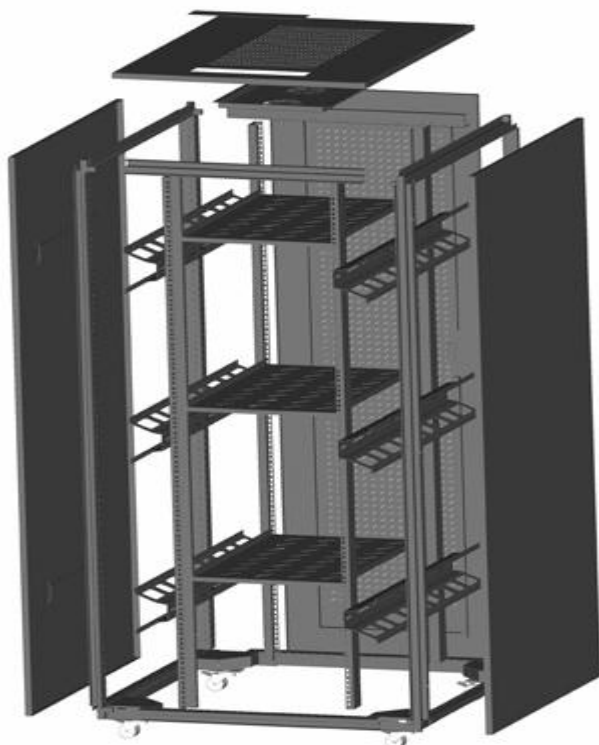

Model No	Capacity (U)	Width (mm)	Depth (mm)	Height (mm)	Packing dimension W*D*H	Volume (CBM)
GN-002-6042	42	600	1000	2055	630*1030*2070	1.3432
GN-002-8042	42	800	1000	2055	830*1030*2070	1.8700

Definition of Color

Color	
RAL9004	Black

GN-002 NETWORK CABINET FREE STANDING 600mm X 600 mm**Product Description**

- Elegant look, profound technical, precise dimension, with modern look, add value to your projects.
- Easy to fix concentrated distribution unit into frame.
- Popular front door made by smoky gray color toughened glass.
- Install caster and support feet at the same time.
- Wire path on the top and bottom can be closed, and wire holes dimension can be changed as request.
- Optional bottom seat for stable stand, bottom wiring, bottom cold ventilation and prevent rats.
- Side door and rear/front door can be taken down easily.

Product Information

Exquisite design with precision dimensions and craftsmanship Color: Computer gray or black, vented front/rear doors enable ventilated operation Swiveling wheels and legs can be jointly installed to withstand up to 800kg maximum carrying capacity and 350kg mobile carrying capacity Several lockable wining holes on top/bottom, size of the large hole at the bottom adjustable Easy-to-disassemble front/rear/left/right doors enable convenient operation from any side of the cabinet Optional installation of base enables the cabinet to stay in a fixed position while meeting requirements of under-base wiring/ventilation Linkage cabinet.

Offering Accessories 19" Rack Height assorted sizes depth 600mm width 600mm accessories 3 fixed shelf, 4 fans 4 castors 4 feet 40 set cage nuts.

Main material: SPCC cold rolled steel; **Thickness of Steel:** mounting profile: 2.0mm; others: 1.2mm.

Surface finish: Surface: degreasing, acid pickling, phosphoric, dip-coat primed, powder coat;

Loading capacity: Static loading: 800KG **Degree of protection:** IP20

STANDARD: Comply with ANSI/EIA RS-310-D、IEC297-2、DIN41494 ;

PART1、DIN41494; PART7、GB/T3047; 2-92STANDARD.

Specifications

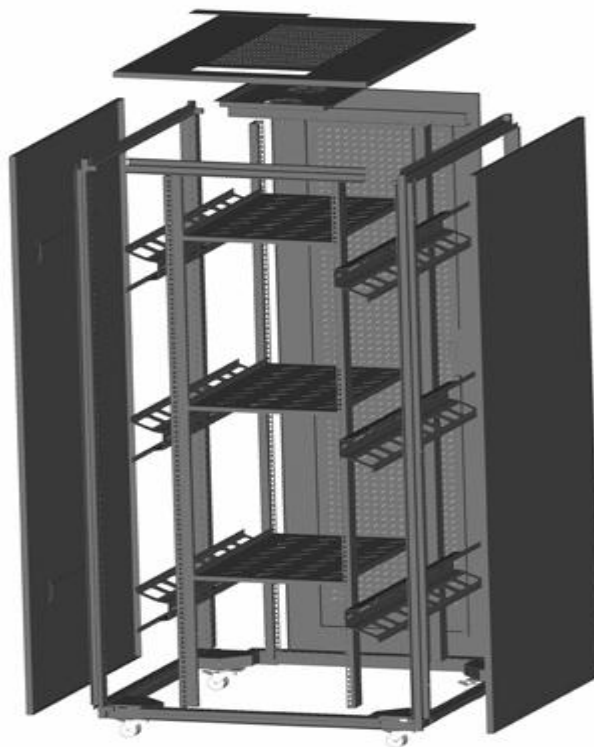

Model No	Capacity (U)	Width (mm)	Depth (mm)	Height (mm)	Packing dimension W*D*H	Volume (CBM)
GN-002-6618	18	600	600	988	630*630*1008	0.3844
GN-002-6622	22	600	600	1166	630*630*1176	0.4459
GN-002-6627	27	600	600	1388	630*630*1403	0.5189
GN-002-6632	32	600	600	1610	630*630*1625	0.6266
GN-002-6642	42	600	600	2055	630*630*2070	0.7881

Definition of Color

Color	
RAL9004	Black

GN-006 WALL MOUNTED NETWORK CABINET

Structure



Product Description

- Double section wall mounted cabinet.
- Quick open side door easy to install and maintain.
- Top and bottom wire path.
- Optional caster and support feet for stand installing.
- Optional 120mm axial motor.
- Convenient and quick wall mounting.

Product Information

- Welded frame, reliable structure.
- Double section wall mount cabinet.
- Standing or wall mounting installation.
- Adjustable feet and heavy duty castors are optional
- Easy mount installation .
- 19" standard installation.
- Removable side panels, side locks optional.
- Cable entry on both of top cover and bottom panel.

Offering Accessories:20 sets cage nuts.

Main material: SPCC cold rolled steel; **Thickness of Steel:** mounting profile: 1.5mm; others: 1.2mm.

Surface finish: Surface: degreasing, acid pickling, phosphoric, dip-coat primed, powder coat;

Loading capacity: Static loading 60KG **Degree of protection:** IP20.

Specifications

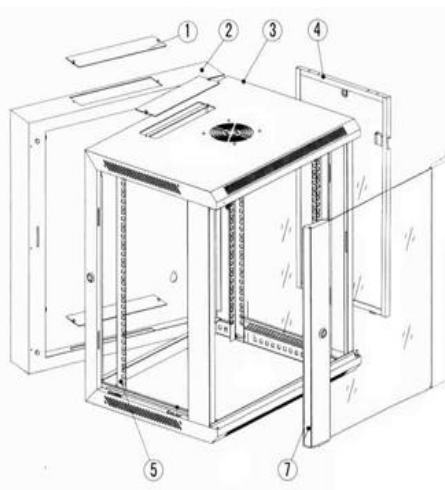

Model No	Capacity (U)	Width (mm)	Depth (mm)	Height (mm)	Packing dimension W*D*H	Volume (CBM)
GN-006-6606	6	600	600	368	630*630*388	0.1937
GN-006-6509	9	600	550	501	630*570*521	0.2923
GN-006-6609	9	600	600	501	630*630*521	0.2923

Definition of Color

Color	
RAL9004	Black

GN-007 WALL MOUNTED NETWORK CABINET

Structures



Product Description

- Wall mount rack.
- Quick open side door easy to install and maintain.
- Top and bottom wire path.
- Optional caster and support feet for stand installing.
- Optional 120mm axial motor.
- Convenient and quick wall mounting.
- Frame structure, max loading 60kgs.

Product Information

- Welded frame, reliable structure.
- Double section wall mount cabinet.
- Standing or wall mounting installation.
- Adjustable feet and heavy duty castors are optional.
- Easy mount installation
- 19" standard installation.
- Removable side panels, side locks optional.
- Cable entry on both of top cover and bottom panel.

Offering Accessories:20 sets cage nuts.

Main material: SPCC cold rolled steel; **Thickness of Steel:** mounting profile: 1.5mm; others: 1.2mm.

Surface finish: Surface: degreasing, acid pickling, phosphoric, dip-coat primed, powder coat.

Loading capacity: Static loading 60KG **Degree of protection:** IP20

Specifications

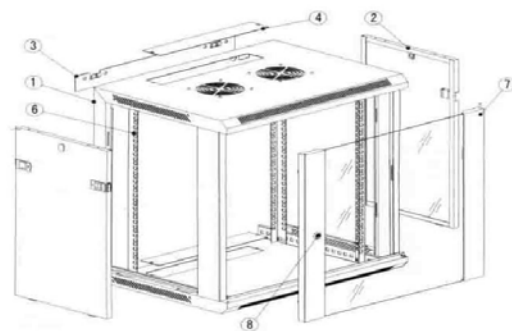

- 1. THE FRAME
- 2. SIDE DOOR
- 3. WALL BRACKET
- 4. TOP COVER
- 5. BOTTOM
- 6. TRAIL
- 7. FRONT DOOR
- 8.

Model No	Capacity (U)	Width (mm)	Depth (mm)	Height (mm)	Packing dimension W*D*H	Volume (CBM)
GN-007-6406	6	600	450	368	630*470*388	0.1211
GN-007-6606	6	600	600	368	630*630*388	0.1603
GN-007-6412	12	600	450	635	630*470*655	0.2812
GN-007-6612	12	600	600	635	630*630*655	0.3272
GN-007-6415	15	600	450	769	630*470*789	0.4052
GN-007-6615	15	600	600	769	630*630*721	0.4105
GN-007-6618	18	600	600	901	630*630*721	0.2104

Definition of Color

Color	
RAL9004	Black

Cabinet Accessories



GN-301-3
Front to back fixed support board



GN-301-16
Cooling Fan



GN-301-07
4 Fan Ventilation Unit



GN-301-22
Castors



GN-301-23
Feet



GN-301-5
Keyboard frame

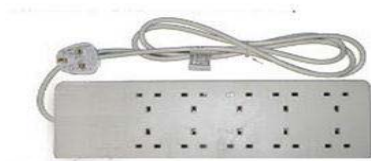

GN-PDU-10
Power Socket



GN-301-14
Vertical Cable Manager



GN-301-24
Screws

NOTES

Lined area for notes, consisting of multiple horizontal lines within a rectangular border.



GIGANET NETWORKING SOLUTIONS LTD.

**UNIT V17
VECTOR PARK
FOREST ROAD
FELTHAM, TW13 7EJ**

CONTACT US

Telephone: +44 (0) 208 616 0246

Sales: sales@giga-net.co.uk

Training Enquiries: training@giga-net.co.uk

Technical Support: support@giga-net.co.uk

AUTHORIZED DISTRIBUTOR



www.giga-net.co.uk